

A series of blurred, overlapping rectangular shapes in various colors (red, orange, yellow, green, blue) arranged in a stepped pattern, suggesting the internal elements of a camera lens.

35mm High Speed Aspherical Lens
INSTRUCTION MANUAL

VIV-35MM-P

Vivitar
SERIES 1

A vertical decorative element on the right side of the page, consisting of several thin, parallel lines in various colors (red, yellow, green, blue, white) running from top to bottom.

Limited Five Year Warranty

Vivitar warrants this quality product to be free of defects in material and workmanship for a period of five years from the date of purchase. During the period, Vivitar will repair or replace the product at no charge for parts or labor.

TIME PERIOD OF THIS WARRANTY

The time period of this warranty starts from the date of the original purchase and expires on the fifth anniversary date of purchase.

WHAT IS NOT COVERED BY THIS WARRANTY

No express or implied warranty is made for any defects in this product which result from accident, abuse, misuse, failure to operate the product in accordance with relevant instructions, neglect, immersion in or exposure to chemicals or liquids, extremes of climate, fungus, excessive wear and tear/cosmetic damage and defects resulting from other extraneous causes such as unauthorised disassembly, repair or modification.

This warranty shall not extend to any incidental or consequential damages arising from the purchase, use or inability to use this product even if Vivitar has been advised of such damages. The laws of some countries and some States thereof do not allow the limitation of incidental or consequential damages, so the above limitation or exclusion may apply to you.

WHAT TO DO WHEN SERVICE IS NEEDED

STEP 1. Package the product and relevant accessories carefully, using ample padding materials and a sturdy mailing container to prevent damage in transit.

STEP 2. Include in package:

- a) Evidence of date and place of original purchase (for example, a copy of your sales receipt).
- b) Detailed description of your problem.
- c) When possible, a sample evidencing the problem.

STEP 3. Return item (insured) to: (in the U.S.):

Vivitar
Attn: Technical Support
195 Carter Drive
Edison NJ 08817

(in the U.K.)

Sakar UK
2D Siskin Parkway East
CV3 4PE, UK

When service is complete, the product will be returned to you shipping prepaid. In the event the product is deemed to be not faulty or the defect is a result in wear and tear, Vivitar may levy a handling charge for the return of the product. This warranty gives you specific legal rights. You may also have other rights which vary from country and State to State thereof. For more information visit our website www.vivitar.com

TECHNICAL SUPPORT

For technical support issues please visit our website at www.vivitar.com. You can find manuals, software and FAQ's at the website. Can't find what you are looking for? E-mail us at support@vivitar.com and one of our technical support team members will answer your questions. For phone support in the US please call 1-800-592-9541, in the UK call 0800 917 4831. If you would like to call from anywhere else, please visit www.vivitar.com for your local toll free number.

Introduction

Thank you for purchasing the VIV-35MM-P High Speed Aspherical Lens. This lens will provide you with many unique and exciting photo taking opportunities which we hope you will enjoy.

Features of Your Lens:

- A floating design that will provide you with sharp images for both long shots and close up shots
- A single glass aspherical lens which can give you crisp looking shots even at periphery angles.
- Two high refraction lenses made of premium optical glass.
- An ultra-multi-coating (UMC) design that suppresses ghosting and delivers clear images.
- Eight aperture stops, enabling effective out-focusing
- Can be used with Pentax film and digital SLR cameras

Your 35mm High Speed Aspherical Lens is designed with its own mount. Users can take photographs easily without installing an additional adaptor by mounting the lens directly onto the camera.

Please read these directions prior to using your lens.

A Quick Look at Your Device

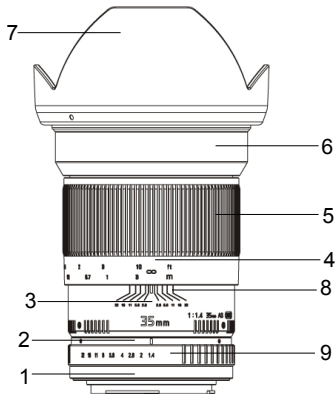

1. Lens Ring Mount (camera locking area)
2. Aperture Value Scale
3. Distance Scale
4. Focus Scaling Ring
5. Focusing Ring
6. Hood Locking Tube
7. Hood
8. Depth of Field Scale
9. Aperture Adjustment Ring

Your VIV-35MM-P lens is uniquely designed for Pentax digital SLR cameras.

Attaching Your Lens to Your Camera

Hold the hood of the lens gently, and align the depth of field scale of the lens with the lens attachment reference point on of the camera. Next, push the lens into the camera and turn the lens carefully until it makes a clicking sound, and the depth of field scale is positioned on the upper part of the camera.

Detaching Your Lens from Your Camera

Hold the hood of the lens gently, and press the lens release button on the camera. Turn the lens in the opposite direction as when attaching, and carefully pull it out.

Focus Adjustment

You can adjust the focus of the subject you are photographing by turning the focusing ring on your lens, as it is an MF (manual focus) adjustment lens. To do so, please follow the steps below:

1. When focusing on a subject from a long distance, turn the focus ring to the right (1 to ∞) and focus on the clearest subject by using the indication signal on the camera or by checking visually.
2. When focusing on a subject from a short distance, turn the focus ring to the left (∞ to 1) and focus on the clearest subject by using the indication signal on the camera or by checking visually.

Brightness Control

You can set the amount of brightness you want by turning the aperture adjustment ring when using your lens.

[Aperture adjustment ring markings]

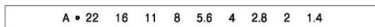

When you turn the aperture adjustment ring between 22, 16, 11, 8, 5.6, 4, 2.8, 2 and 1.4 you are making 1 stop each turn. Brightness can be set more precisely by making half stops as well (see below).



5.6 and 8 are 1 stop apart (1EV).

Set a 0.5 stop (0.5EV) between 5.6 and 8

Camera Settings

Some cameras require special settings when using this lens. Please read the information below and set your camera accordingly.

Av mode: the mounts on your lens supports Av mode.

1) Align the A mode indicator to the depth of field scale by pressing the A button on the aperture adjustment ring of the lens.

2) Set the mode dial of the camera to 'Av'.



Camera Settings (continued)

3. Set the focus adjustment lever of the camera to MF

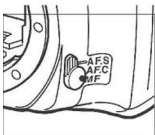

4. Set the menu on the camera.
5. Adjust the brightness by turning the dial at the back of the camera.

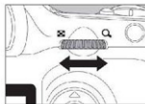

(The camera settings discussed apply to the Pentax K20D camera. Settings for the camera or the menu may be changed depending on the model or due to a menu upgrade. Refer to your camera manual or contact the camera manufacturer for more detailed information.)

Mounting the Hood

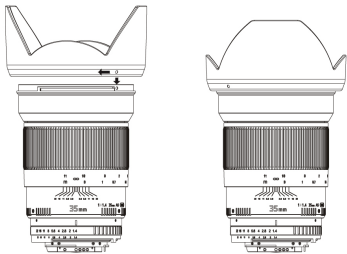

The hood has a bayonet system, which guarantees speedy, efficient, safe and precise installation and will help you take shots that are free of flaring and ghosting. Align the attachment reference point on the hood with the reference point on the lens. Push the hood onto the lens and turn the hood to the right until it makes a clicking sound.

Specifications

- 35mm f/1.4
- Aperture Range F1.4-22
- Diagonal View Angle: 63°
- Weight: 1.64lb
- Diameter x Length: 83 x 110mm

- Uses 77mm Filters
- Minimum Focusing Distance: 0.3m (1ft)
- Maximum Diameter: 83mm
- Construction: 12 Elements in 10 Groups

Troubleshooting

Phenomena	Causes	Measures
A lens can't be attached to the camera.	The lens ring mount and the camera mount are not aligned.	Align the lens ring mount and the camera mount.
A lens can't be detached from the camera.	Incorrect rotation direction for detaching. If the user turns the lens while holding the camera, it may cause damage to the lens.	Press the lens release button on the camera, and lightly turn the lens to the lens attaching and detaching reference points, in the direction as marked on the camera, and then pull the lens forward.
Dark image	Incorrect focusing. Insufficient shutter speed or camera shake.	Turn the focus ring while checking the indication or checking an object visually, set the focus until it reaches a clear point, and then press the shutter. Steady the camera and take a photograph at a shutter speed of 1/125 secs.
Autofocus failure	Autofocus failed with a manual control focus lens.	Set focus by turning the focus ring.
Dark or too bright pictures	Inappropriate exposure	Adjust the aperture size.

Troubleshooting (continued)

Phenomena	Causes	Measures
Dark or too bright pictures	Inappropriate exposure	Adjust the aperture size.
The periphery gets dark when using a manual camera or a digital camera for 1:1 image sensor.	As this lens is optimized for APS-C size images, so the periphery gets dark when using a digital camera for 1:1 size images.	Use a digital camera for APS-C size images.
The camera flash is not geared to the camera.	The manual control lens may not be compatible, depending on the camera.	See the camera manual.
The camera finder indication or the display is not displayed.	This lens doesn't have an electric contact signal, so there is no communication with the camera through electric signals.	No problem with shooting.
Zooming failure	This lens is a single lens.	
The lens hood can't be detached.	This lens hood and the lens body are a fixed type, so the lens hood can't be detached.	
This lens can't be mounted on other cameras.	This lens is designed for its own mount.	Purchase the required lens mount.

Caution

The following precautions are divided into two types according to the level of danger.

⚠ WARNING

If this instruction is not followed, it may cause death or severe injury to the user.

⚠ CAUTION

If this instruction is not followed, it may cause death or severe injury to the user.

The following pictograms are used in the below precautions:



Requires caution. Inside the pictogram it shows contents of precautions. (It shows outbreak of fire in the pictogram on the left.)



Shows prohibition. Inside the pictogram it shows contents of prohibition. (It shows prohibition of dismantling in the pictogram on the left.)



Shows instruction. Inside the pictogram it shows contents of instructions. (It shows instruction of precaution in the pictogram on the left.)

⚠ WARNING

⊘ Don't look at the sun through the lens. It may cause blindness.



⚠ CAUTION

⚠ Attach the lens to the camera correctly and ensure the lens is held in place properly; otherwise the lens may not be removable, or may become loose and cause an accident.



⊘ Don't put excessive pressure on the lens attached to the camera; otherwise it may cause damage to the lens or to the camera mount. Be sure to hold the lens when operating or moving.



⚠ Ensure that the camera operates properly by checking the lens beforehand or by test shooting for important events such as a wedding ceremony and an overseas trip.



⊘ Don't leave the lens within reach of babies, as it may cause injury to the baby if the lens falls or is dropped.



⊘ Don't attempt to modify or alter the lens. It may lead to failure of the camera. Modified or altered lenses may not be repaired.



⊘ Don't leave the lens in direct sunlight. It may cause a fire, depending on lenses that concentrate light on a close object.



⊘ Don't look at the sun directly through a camera with a lens attached. It may cause damage to one's eyesight.



Caution

WARNING!

Don't wet this product or expose it to a moist environment. It may cause a fire or electric shock.

CAUTION!

- Don't use this product or store it close to devices that generate heat i.e., heaters, thermal regulators, stoves, stereo amplifiers.
- Don't leave the lens in conditions where drastic temperature changes can occur.
- Don't touch the surface of the lens by hand, and avoid making contact with sharp objects.
- Avoid dropping the lens.
- Don't soak the lens in water, and avoid water splashing onto the lens.
- If there are foreign bodies on the lens, use a lens cleaning kit only.
- If the lens hood is cut by the user, it may cause damage to the surface of the lens, as the surface of the lens may make contact with the floor.

Vivitar[®]
SERIES 1